

*For unprecedented ease and economy of serial alarm system installation, periodic testing, troubleshooting and training, small network monitoring and control...*

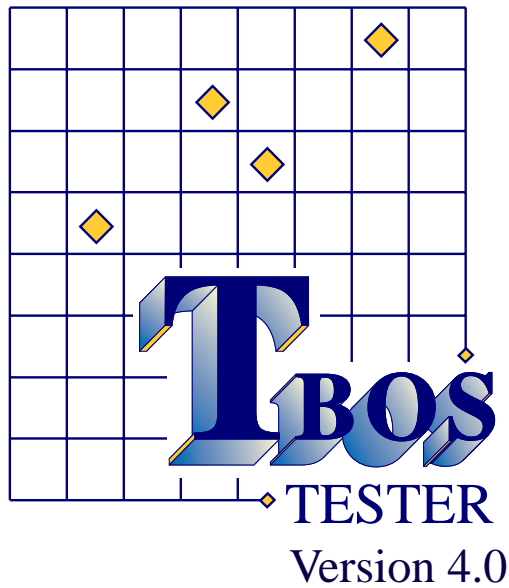

## Now you can generate, monitor and analyze TBOS E-telemetry with a PC or laptop!

---

- ✓ Gain local access to TBOS data conveyed to the Central. TBOS Tester™ reveals on screen which alarms are active, compiles alarm histories during extended tests and can provide remote notification via terminal or alphanumeric pager when designated alarms occur, all without interrupting, relying on or waiting for central monitoring systems.

### **Overview .....**

TBOS Tester™ is a complete package of software, hardware and cabling that enables your IBM-PC® compatible or laptop computer to generate, monitor and analyze TBOS (serial E-telemetry) alarm messages. By harnessing the inherent capabilities of a personal computer, TBOS Tester™ is more powerful and versatile than traditional, dedicated TBOS test equipment (as well as easier to transport and use) yet *far* less expensive.

### **Typical Uses .....**

- ✓ Verify newly installed monitored equipment TBOS functions without help from Central personnel. TBOS Tester™ lets you make sure monitored equipment is outputting serial alarms and is correctly addressed before you connect it to an alarm remote.
- ✓ Troubleshoot serial alarm systems *locally* without assistance from the Central. Quickly diagnose and isolate configuration, wiring and timing problems or equipment failures. TBOS Tester™ reveals in moments whether a problem lies with the Remote or the monitored equipment.
- ✓ Test alarm remotes by generating simulated alarms for the Remote to scan. TBOS Tester™ lets you test *all* scan points without actually creating alarms on live equipment.

- ✓ Inexpensively monitor and control small offices or networks using TBOS Tester™, or add serial alarm data to your existing network management system. Scan for alarms and send maintenance commands to as many as eight network elements at a time. Use a direct local link to monitored equipment, a dedicated circuit to remote sites, the integrated autodialer or even a dial-in link. TBOS Tester's alarm acknowledgment, history and remote notification features provide a surprisingly powerful, low cost alternative to conventional alarm reporting systems.

- ✓ Test TBOS-compatible equipment during development, manufacture or QC. TBOS Tester™ automatically generates test records, while precision timing controls let you study system behavior at protocol limits.

- ✓ Enhance training on serial alarm systems with TBOS Tester's intuitive, quasi-graphical displays and in-depth documentation.

### **Product History .....**

Since its introduction in 1987, TBOS Tester™ has found broad acceptance at RBOCs, independents, IXCs, cellular providers, CAPs, power utilities, equipment manufacturers and telecom training facilities throughout North America and beyond. TBOS Tester™ is fully compatible with applicable sections of AT&T PUBs 49001, 43804 and CB149, and is certified Year-2000 compliant.

## How TBOS Tester™ works .....

TBOS Tester™ can be connected in three distinct physical configurations and operated in four different test modes to match your application.

### Monitor a TBOS Interconnect

Bridged to the serial data link between a Remote and one or more monitored equipment elements (Figure 1), TBOS Tester™ detects scan and command requests from the Remote and correlates them with monitored equipment responses. Monitor Mode is the perfect tool for serial alarm system troubleshooting, revealing at a glance which network elements are being scanned, whether they are responding and which alarms are active. It also provides local access to serial telemetry without disrupting information flow to the Central.

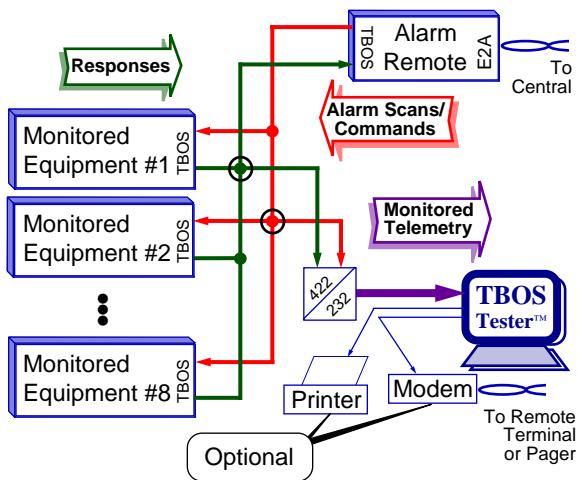

**Figure 1: Monitor Mode**

With its RS-232 to 422 converter operating as a dual channel receiver, TBOS Tester™ reveals the content of telemetry exchanges between an alarm remote and monitored equipment.

### Scan for alarms or send commands

More than a monitoring device, TBOS Tester™ can also emulate or even replace an alarm remote (Figure 2). In Display Mode TBOS Tester™ issues scan requests to as many as eight network elements, collecting and displaying their replies. When operating in Command Mode TBOS Tester™ lets you select and send momentary or latching relay commands to the monitored equipment and verify acknowledgments.

During installation and turn-up the display and command modes let you verify TBOS functions for monitored equipment *before* it is connected to an alarm system. When troubleshooting an existing alarm system TBOS Tester™ provides *local* control of alarm scanning and command generation with immediate performance feedback, and allows alarm system elements to be isolated for testing with minimal disruption to the rest of the alarm system.

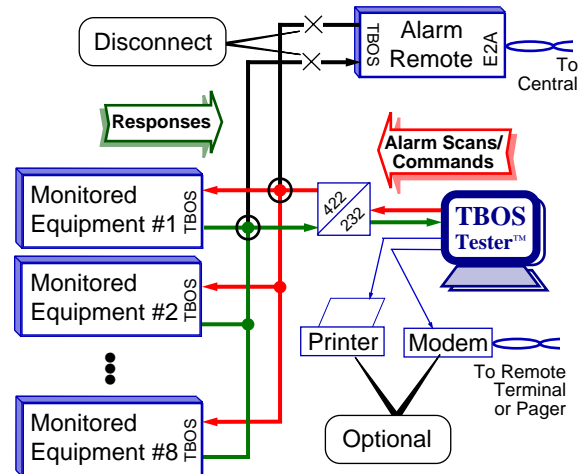

**Figure 2: Display and Command Modes**

With its converter operating as a transceiver, TBOS Tester™ generates scan and command requests (in lieu of the alarm remote) and gathers replies from the monitored equipment.

### Generate serial alarms

TBOS Tester™ can verify alarm remote functions as well. Connected by itself or in parallel with monitored equipment (Figure 3) and operated in Respond Mode, TBOS Tester™ receives scan and command requests from the Remote and generates responses for as many as eight addresses. You can tailor scan replies to the Remote by selecting any number of individual alarm points to be reported active.

Respond Mode lets you verify that *all* alarms are being accurately conveyed to the Central and that command requests are being received and relayed to the monitored equipment, all without actually connecting the Remote to the network. This eliminates the need to generate test alarms by pulling modules, and the risk of connecting a partially tested Remote to the network.

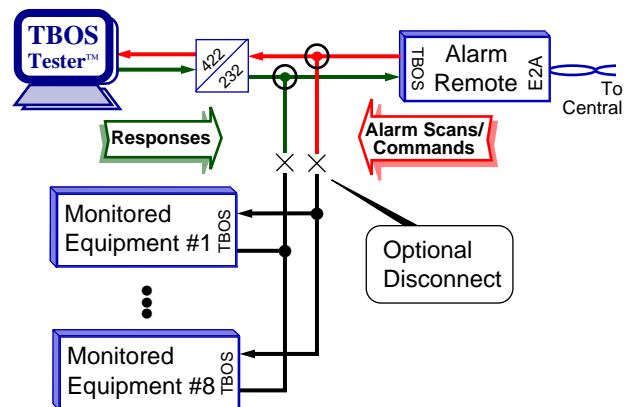

**Figure 3: Respond Mode**

TBOS Tester™ generates replies to scan and command requests from the alarm remote in parallel with or in lieu of monitored equipment.

## Information Display .....

Test data can be worthless unless presented in a format that allows the data to be quickly and accurately interpreted. TBOS Tester™ offers a variety of ways to view test results and network status. It is *much* easier to use than conventional protocol analyzers or other TBOS test equipment, yet powerful enough to be a stand-alone monitoring system for small networks.

- The 64 scan points that comprise each TBOS display and command address are shown on screen as a grid reminiscent of a checkerboard (Figure 4). Active alarms appear in reverse video. Two types of **scan indicators** reveal at a glance whether TBOS transactions are actively occurring. The display addresses scanned during a test as well as the address currently being scanned are indicated at the bottom of each screen. In addition, the point grids reflect which character (set of eight points) is currently being scanned.

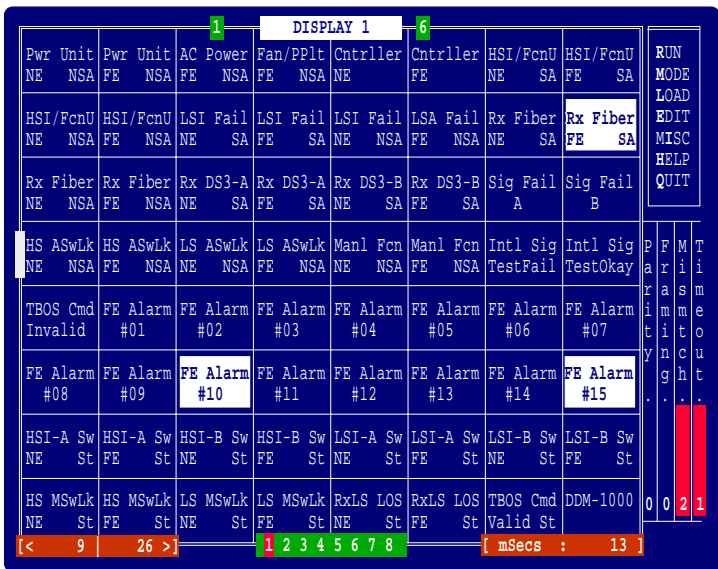

**Figure 4: Alarm Display Grid**

Three active alarms on Display 1 are shown as reverse video blocks. The page activity indicators at the top of the grid show that Display 6 also has alarms. The scan indicators at the bottom and on the left edge show the 4th of eight characters on Display 1 is currently being scanned. Error counts and response time data are also shown.

Alarm point descriptions are specific to the monitored equipment, and once typed are saved in configuration files. Point numbers (1-64) can also be displayed by pressing a key.

Each grid box contains a description (up to 16 characters) of the corresponding alarm or command, eliminating the need to consult equipment manuals during a test in order to decipher TBOS telemetry. Switch the display between point descriptions and point numbers with a single key.

You can create custom screen displays for your specific equipment and test sites with TBOS Tester's alarm and command point description file editor. Copy and move individual pages of point descriptions within or between files to minimize typing.

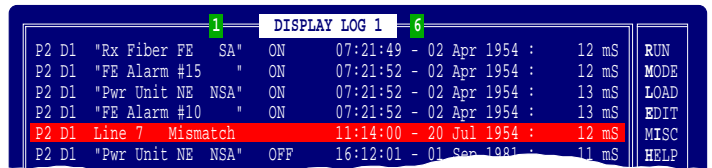

**Figure 5: Log Window**

Events for Display 1 (see Figure 4) appear in log format. The log tells you when the three existing alarms occurred, but also that an additional alarm occurred and cleared.

- A **global view of alarm activity** is provided in two ways. First, the number of each address that contains active alarms appears at the top of each screen. These indicators (as well as an optional audible alarm) provide notification as soon as an alarm occurs, even if the alarm is on a display address not being viewed. In addition, the **master page display** shows individual alarms from all eight TBOS displays on a single screen.
- In contrast to the alarm point grids (which indicate *current* status) the TBOS Tester™ **event log** captures and reports data over time. Each alarm point change, command and protocol violation is time stamped and listed with the associated point number or its meaning. Logs can be written to disk and viewed in their entirety after a test as well as printed during or following a test. During a test the **log window** (Figure 5) lists the most recent events for any single display or for all displays. The event log can also be used with the autodialer feature for remote alarm reporting to a dial-up terminal.
- For detailed studies and troubleshooting, the **data-scope window** displays TBOS telemetry in hex format (Figure 6). You can view telemetry for one or all addresses, and freeze the datascope for study without interrupting alarm scans.

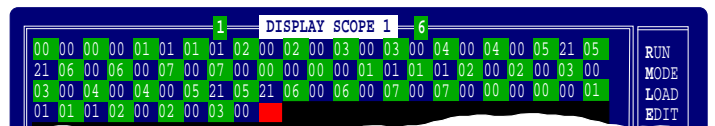

**Figure 6: Datascope Window**

Here data for Display 1 (see Figure 4) is reduced to hexadecimal format. Scans, responses and errors appear in contrasting shades or colors; in this instance scan bytes are green/shaded. The duplicate scan and response pattern that characterizes TBOS telemetry is clearly evident.

## Special Features .....

- For remote alarm reporting applications, TBOS Tester's **autodialer** can call a remote terminal or an alphanumeric pager when TBOS alarms occur that fall within any of eight user-specified ranges of scan points. You can define eight-deep ring down lists should the primary terminal or pager fail to answer. The autodialer will send the pager a predefined message of up to 44 characters describing the nature of the alarm (e.g. which range is active) or download the event log to a remote terminal, beginning with the event that triggered the call. The Autodialer can be extremely useful when running overnight or extended tests, for remote testing or when maintenance personnel must leave a site. For small network monitoring applications the Autodialer provides immediate, 24 hour notification of alarms at unmanned locations.
- For hands-free testing of alarm remotes, the **auto-respond** function activates and deactivates each scan point in succession while the event log creates a test record for later examination. **Global respond point control** allows all alarm points to be activated or deactivated with a single keystroke without interrupting a Respond Mode test. **Respond point files** of active alarm points can be created and saved for repetitive use.
- **Error detection** and reporting for four types of serial telemetry errors is provided on screen and in the event log. These include timeouts, polling mismatches, framing and parity errors. Error counters can be reset from the keyboard without restarting a test. Choose from three **on-error behavior** options to best serve test or monitoring applications: when protocol violations occur scans can continue with the next character, display address or scan cycle.
- To **reveal timing problems** a one millisecond high resolution timer measures the interval between each scan request and reply. The minimum, maximum and current times are displayed on screen, and log entries include any measured transaction times. Four **timing options** let you control and optimize TBOS Tester™ in a wide variety of situations. Two scan delay timers allow measured delay to be added between polling cycles or between scan requests issued in Display Mode. Scan replies issued in Respond Mode can be delayed by measured amounts, and the timeout interval can be adjusted from the 200 millisecond TBOS standard.
- In Display Mode a **single scan** option halts alarm scanning after one complete cycle, providing "snapshot" views of system conditions. The display and command modes have **self-test** options that allow a loopback to be set from the keyboard, providing a convenient means to verify software settings and host computer operation.

- **Adjustable settings** for baud rate (up to 38.4 Kbps), parity and stop-bits are provided for specialized applications. All of the software settings that comprise a test profile are controlled from setup menus. **Multiple profiles** can be defined, eliminating repetitive changes to test setups.
- Menu based **on-line help** lets you view on screen virtually any information you need to operate TBOS Tester™ and interpret test results. The **200 page User's Manual** provides step-by-step instructions for those using TBOS Tester™ for the first time, and detailed information organized by subject for veteran users.

## Hardware Accessories .....

TBOS Tester™ includes all the hardware and cabling needed to test most TBOS-compatible serial alarm system elements. A special purpose RS-232 to RS-422/485 converter, a 25 pin gender changer, 9-to-25 pin adapter cable and a 4-lead wire-wrap pin TBOS interface cable are provided. An optional cable set is available for equipment utilizing a D-connector serial alarm interface. TBOS Tester™ runs on virtually any IBM-PC® compatible with a serial port and DOS 3.2 or later, Windows 3.1® or Win95®. Color, monochrome and LCD screens are supported.

## How to Order .....

The TBOS Tester™ version 4 package of software and hardware accessories is available from TSA for just \$895. Unlimited, perpetual telephone support is provided at no charge; hardware accessories are guaranteed for one year. Registered owners of an earlier version TBOS Tester™ can upgrade their software or hardware at substantial savings.

To order simply mail or fax your purchase order to your sales representative or to TSA (Common Language vendor code TYSW), or call us with your PO number, shipping and billing address. Most orders are shipped within 24 hours.



Telephony Software Associates, INC.

4701 Willowtree Lane  
Clayton, NC 27520  
United States of America

(919) 553-TBOS [553-8267]  
FAX: (919) 553-9095  
tsa@aol.com